

Li-ionSystems

Lithium-ion traction batteries

LITHIUM-ION TRACTION BATTERIES

FOR WAREHOUSE VEHICLES

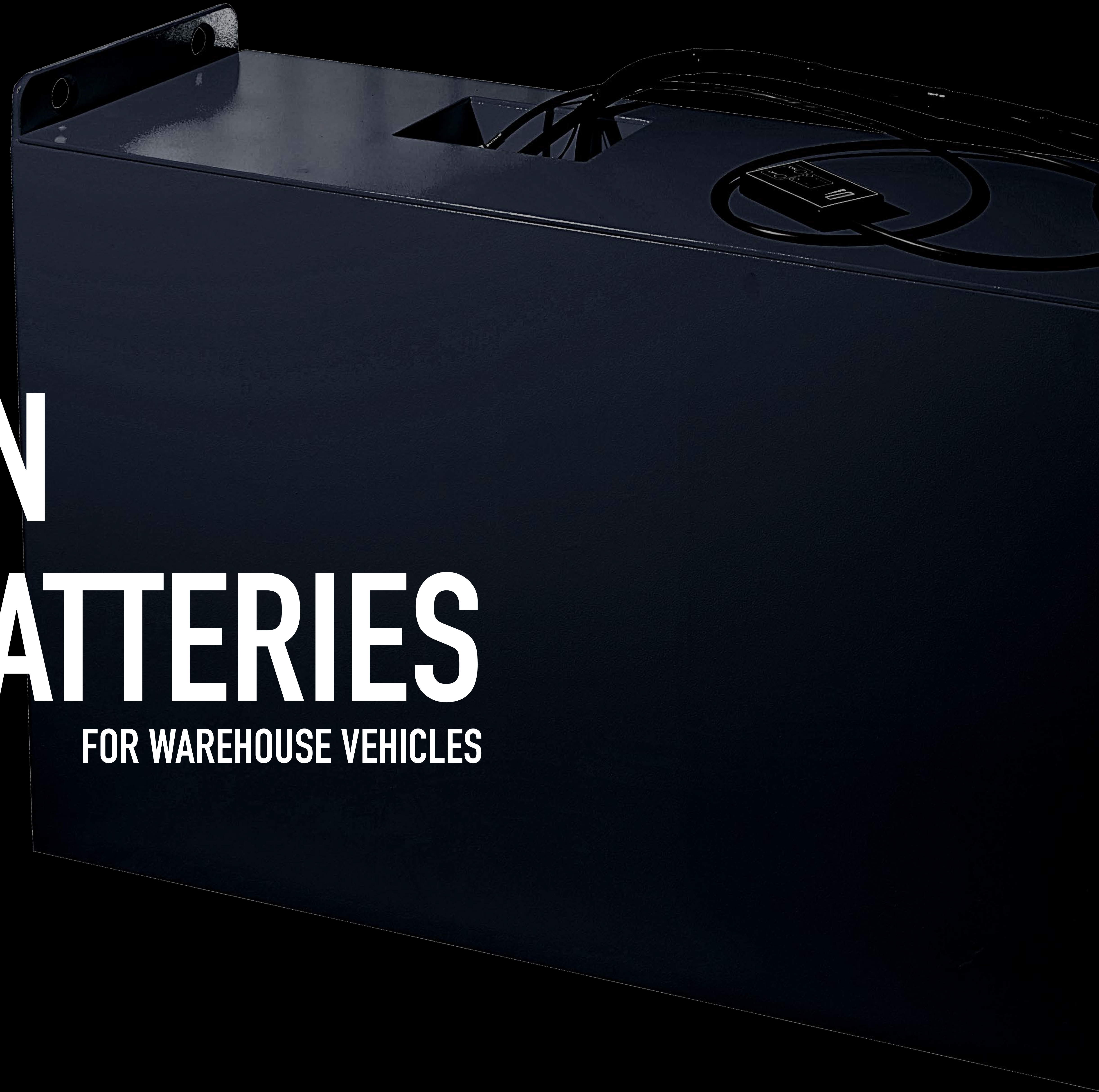

ABOUT

Highly professional Russian company developing, producing and selling energy storage devices based on lithium-ion batteries for modernization of industrial electric vehicles.

The Company conducts continuous research that makes it possible to improve the product quality.

LI-ION SYSTEMS cooperates with specialized educational institutions to hire a qualified staff.

Advantages



JOB EXPERIENCE

For 8 years of work in the Russian market, we have accumulated solid experience and knowledge

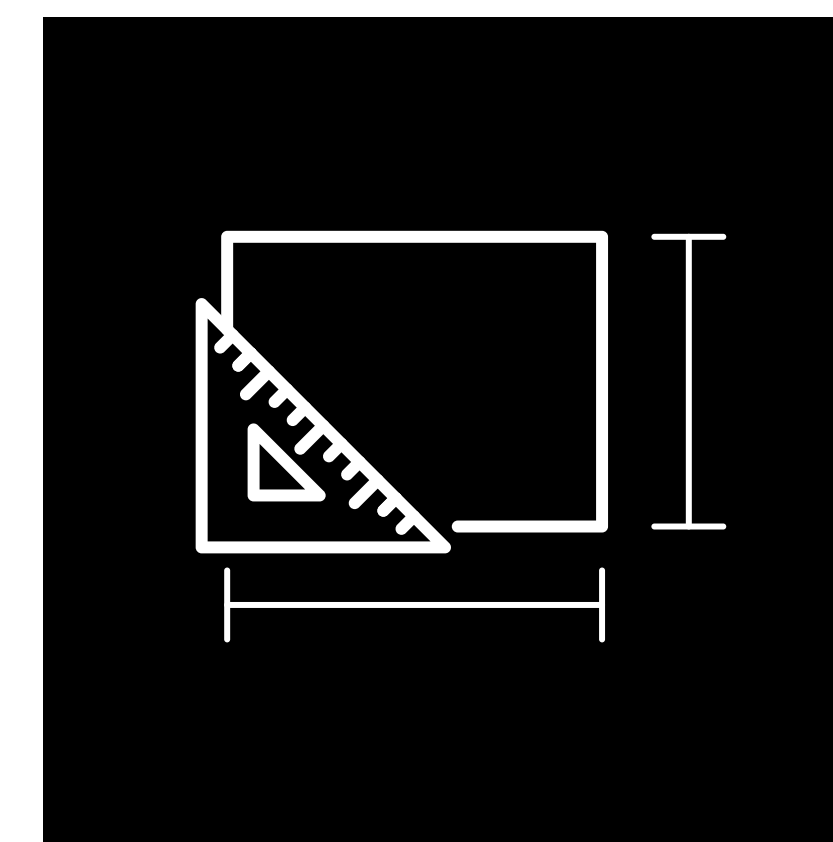

DESIGN OFFICE

In-house design office develops effective solutions

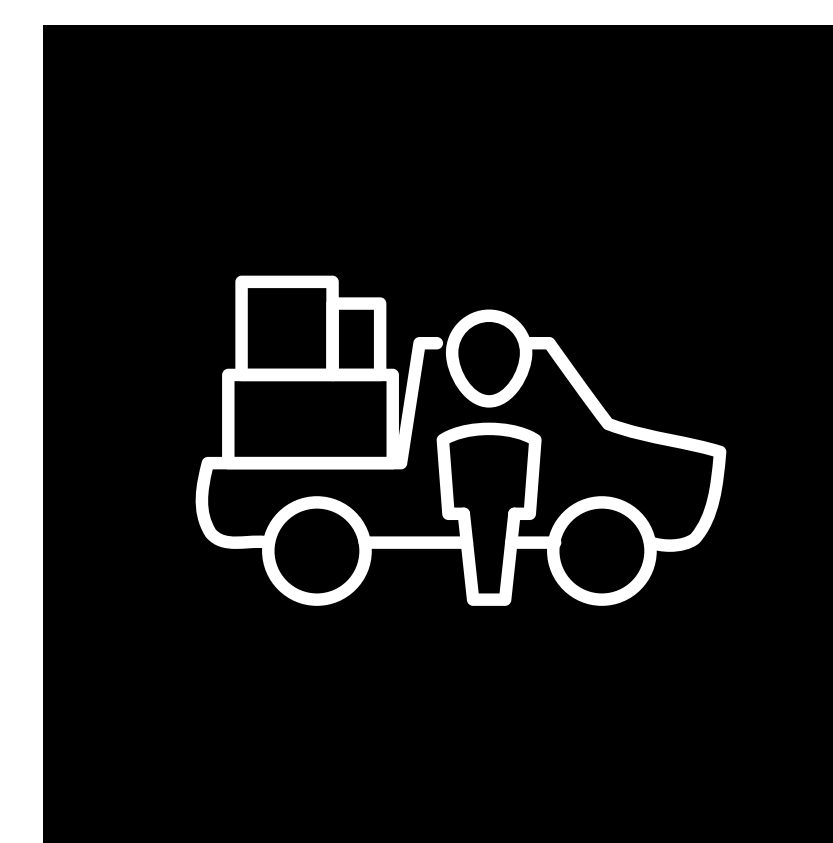

MAJOR CUSTOMERS

We have a well-established customer base, and a long-term cooperation basis

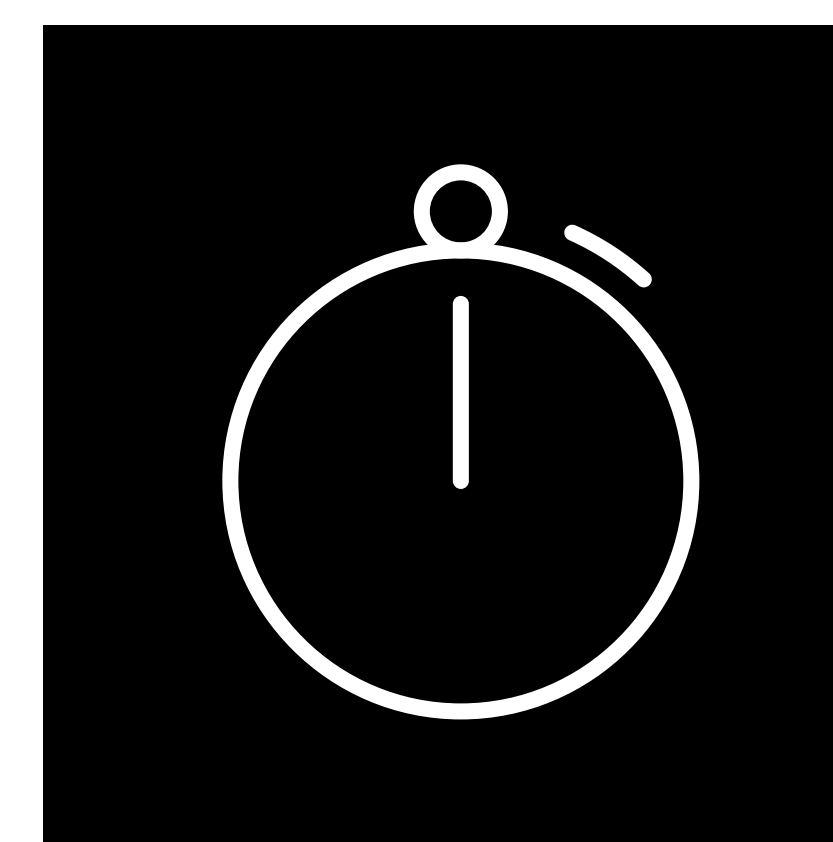

PROMPT PRODUCTION

Average product delivery time starts from 2 weeks (including development taking into account your specifics)



MILESTONES OF THE COMPANY

We work to make your business more successful. Every year our products become more and more perfect and reliable, and service - more convenient.



2019

Creating energy storage device for operation at negative temperatures down to -35°C , including electric heating

2020

*Creating online monitoring system
Successful completion of certification audit for compliance with ISO 9001:2015 standard*

2018

Development of a bidirectional converter complex intended for building local networks of DC/AC consumers

2017

*Introduction of a lean manufacturing system
Transfer of production to the Saratov region
Certification of own commercial electric vehicle based on Gazelle NEXT*

2015

Creating a BMS of own production

2016

Participation in creation of a prototype of electric bus

2014

LI-ION SYSTEMS products are presented in the territory of the CIS countries for the first time

2013

*Creating a charging device of own production
Participation in the development of the first in Russia UPS based on lithium batteries with a capacity of 120 kVA*

CERTIFIED PRODUCTS

The Company has all necessary permits and certificates, including non-obligatory ones

- Certificate of the quality management system compliance with the requirements of ISO 9001: 2015
- Declaration of Conformity to the requirements of CU TR 004/20011, CU TR 020/2011
- Declaration of Conformity to GOST 12.2.007.12-88, GOST R IEC 62133-2004, GOST R IEC 61436-2004, GOST R IEC 61951-2-2007, GOST R IEC 61960-2007
- Statement on fire and explosion safety of accumulating energy storage issued by the Federal State Budgetary Institution VNIPO of the Ministry of Emergency Situations of Russia
- Certificate of compliance with requirements of GOST R; 27483-87, IEC 60335-1- 2015, IEC 60695-10-2-2013
- Certificate of compliance with requirements of GOST R



Certificates at web-site



CERTIFICATE



hereby certifies that the company

Li-ION Systems, LLC

Stroiteley Avenue 32B 413121, Engels, Russian Federation

has implemented and uses
Quality management system

Activity types:
Production of energy storage devices based on lithium batteries and chargers

Through the audit documented in the report, it was confirmed that this management system meets requirements of the following standard:

ISO 9001 : 2015

Certificate registration number	31102047 QM15
Valid from	2020-12-07
Valid until	2023-12-06
Certification date	2020-12-07



DQS GmbH

Markus Bleher
Director General

Accredited Body: DQS GmbH, August-Schanz-Straße 21, 60433 Frankfurt am Main, Germany
Administrative Office: OOO SSU DEKUES, Republikanskaya str. 3, 150003 Yaroslavl, Russian Federation

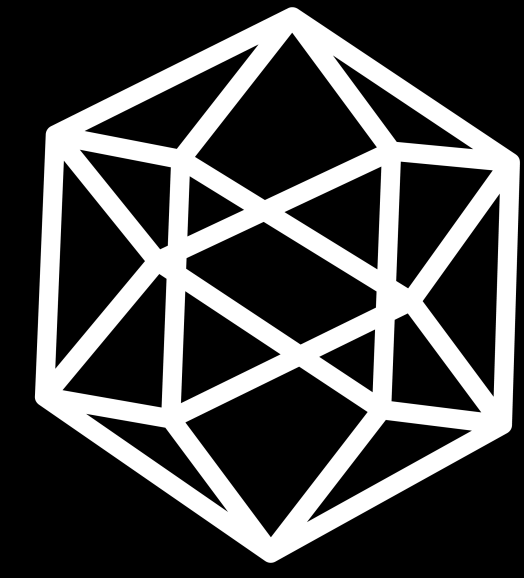

Li-ionSystems

Lithium-ion traction batteries

TECHNOLOGIES

Use of innovative solutions makes the products of LI-ION SYSTEMS efficient and trouble-free

LI-ION SYSTEMS batteries

are **POWER, RELIABILITY**
and **SPEED**

Introduction of LI-ION SYSTEMS' solutions allows getting maximum efficiency of the warehouse equipment fleet



PROCESS DESIGN

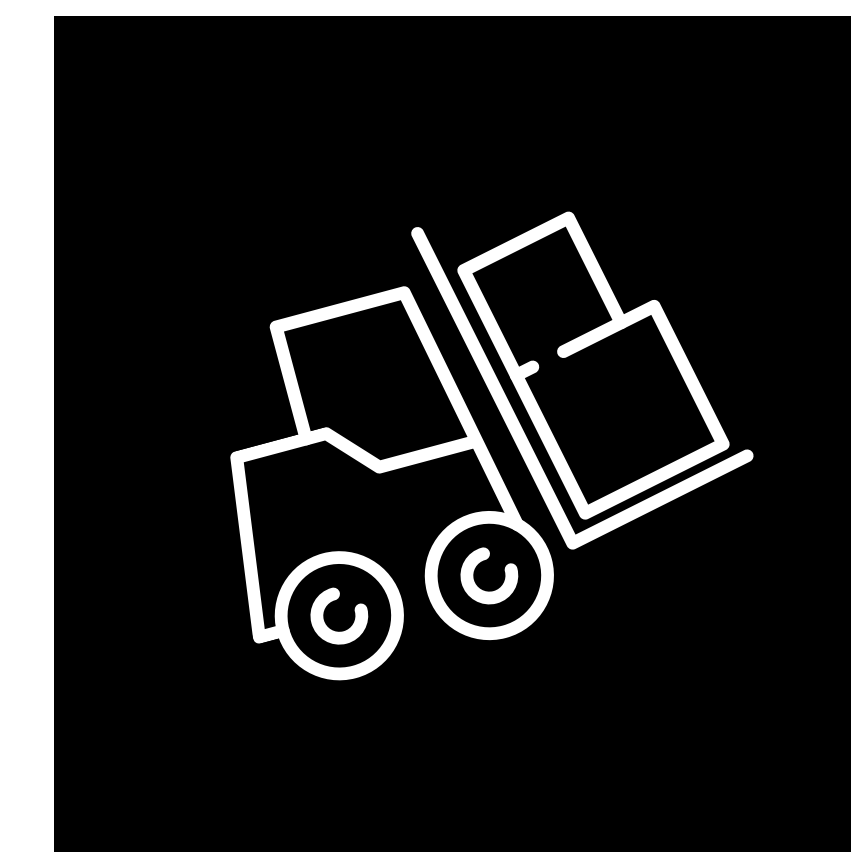

NO EFFECT OF VIBRATIONS AND TILTS

Design solutions used exclude possible damage to the cells and electronic components at vibration and extreme inclination angles of the storage device during operation together with the equipment.

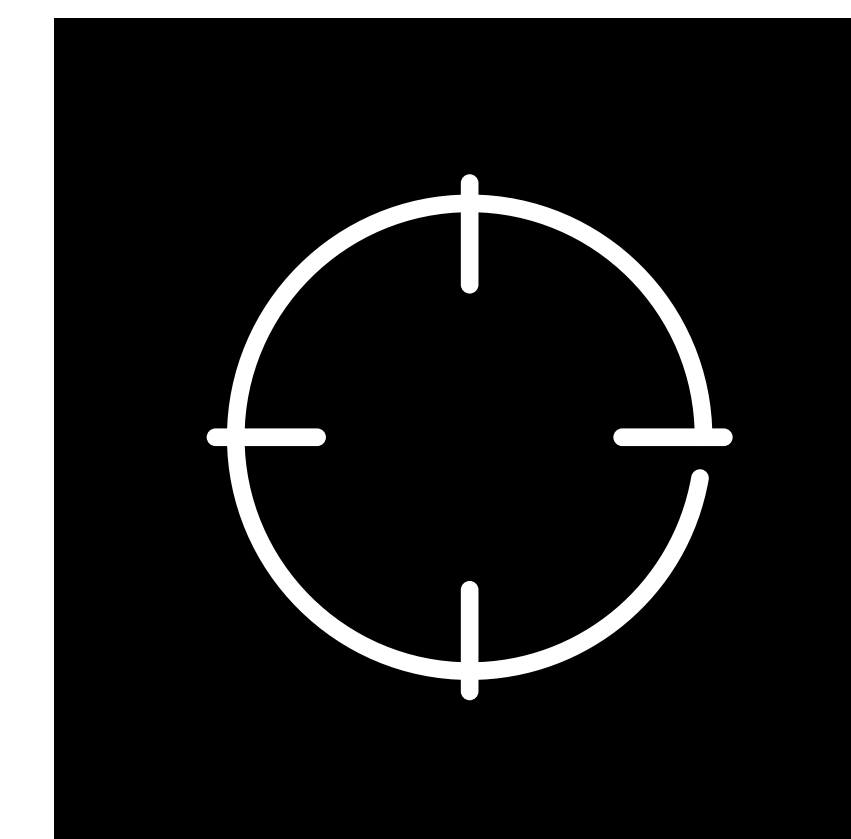

PERFECT BALANCE

Optimal weight distribution is achieved by careful 3D-modeling and design of the structure. The energy storage device center of gravity is located exactly in the center of the housing that allows avoiding overweighting on one of the sides, and as a result, preventing energy storage device from tipping over during transportation and eliminating excessive load on one of the axes of the loader.

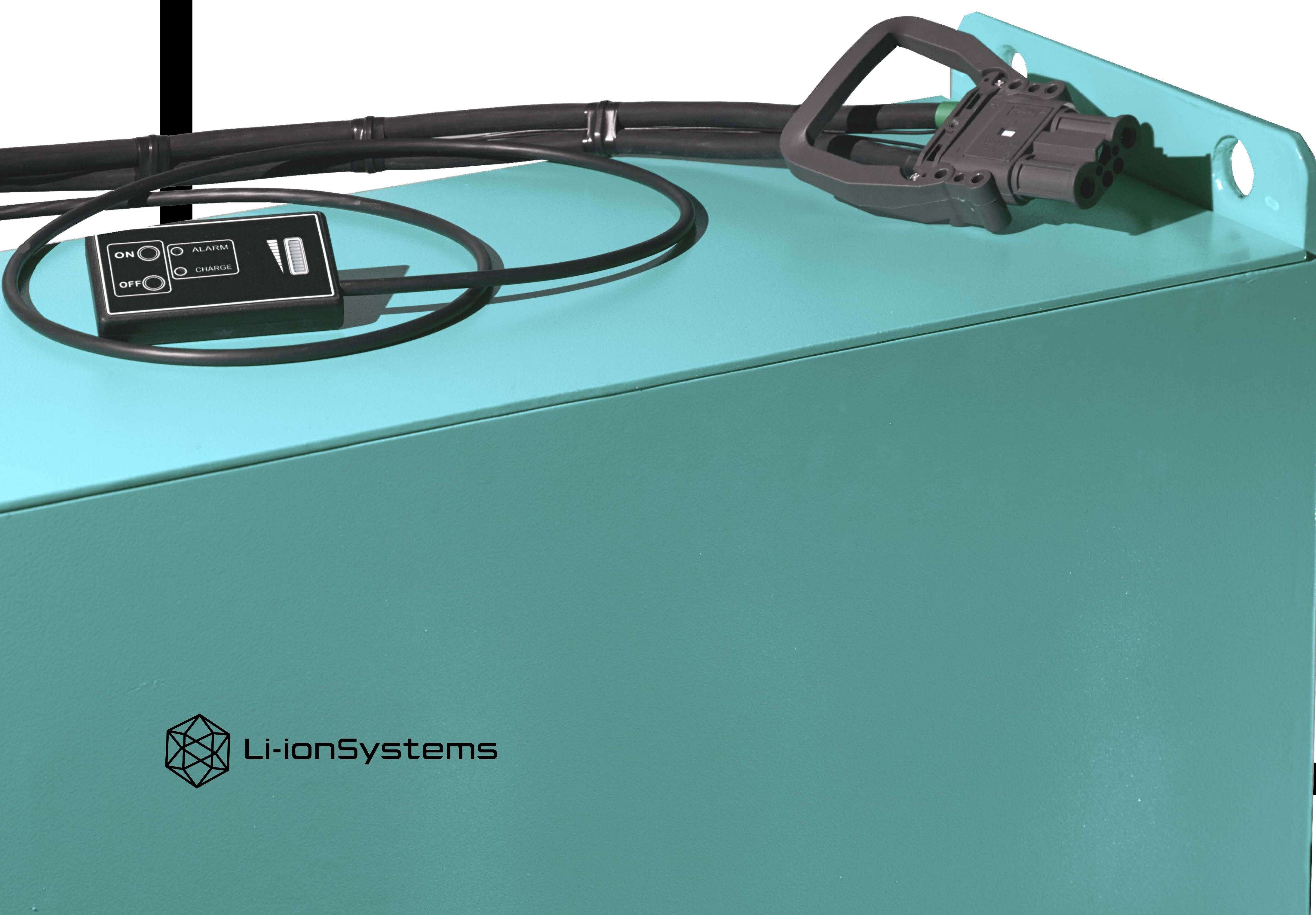



HIGH-QUALITY COMPONENTS

LI-ION SYSTEMS uses only high-quality cells with a rated voltage of 3.2 V from such manufacturers as Calb, Eve, ETC. LiFePO₄ elements used can operate stably over a wide temperature range, even at extreme weather conditions.



CONTROL SYSTEM OF THE ENERGY STORAGE DEVICE

The control system primarily controls charge / discharge process of the energy storage device and is responsible for the battery safety, monitors condition and evaluates data on the battery's health.

VMS of own production guarantees reliable control, effective control of balancing, storage of data in the event log during the period of operation that allows improving quality of LI-ION SYSTEMS' energy storage device operation.

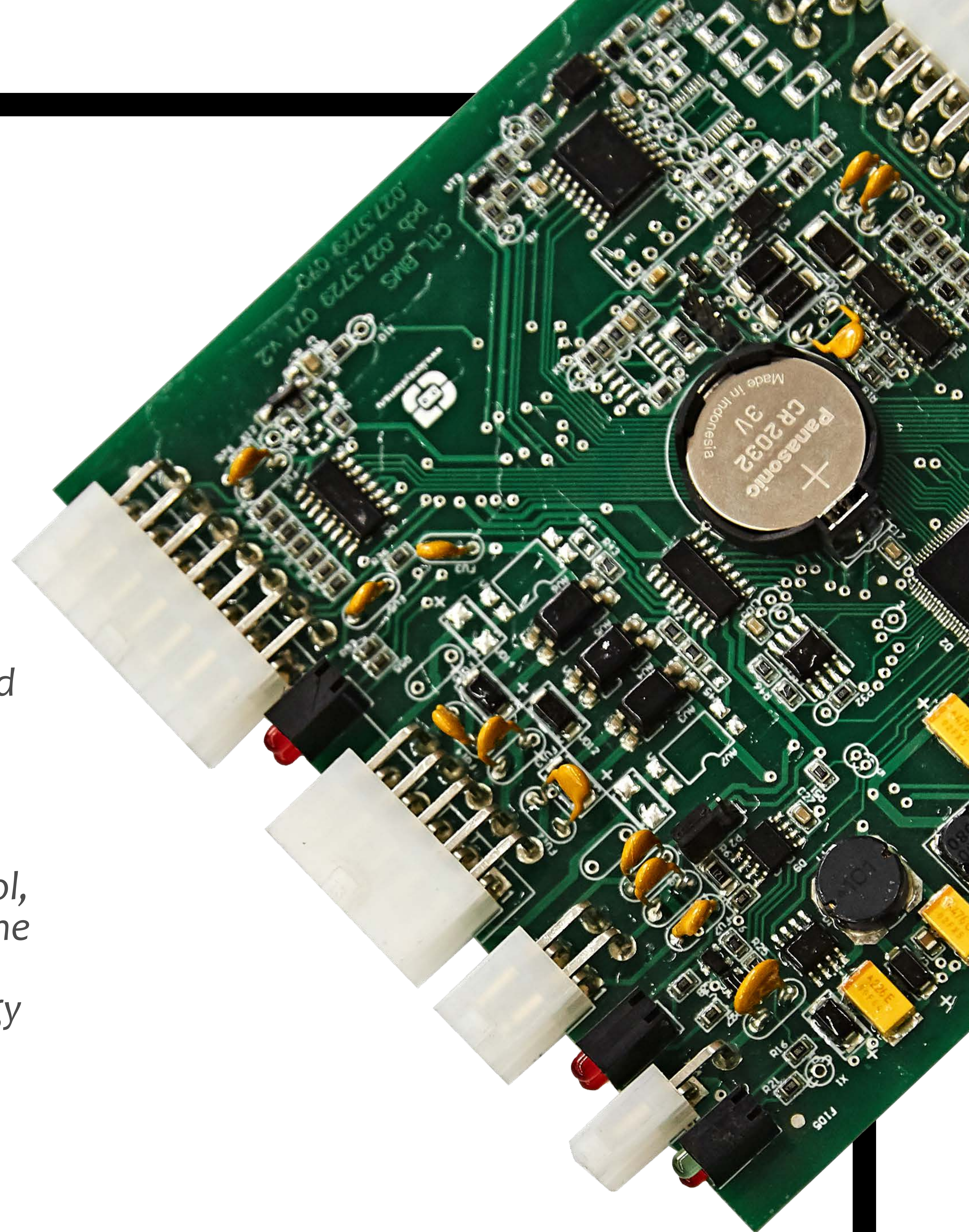

ACTIVE BALANCING

To operate energy storage devices, it is necessary to use balancing devices which reduce voltage imbalance between the cells to a minimum. The unbalance has a tendency to increase with each charge/discharge cycle.

Active balancing allows redistributing energy inside the battery and can work both during discharging, and charging operation.

The energy is redistributed from the battery having a large capacity to the battery having a smaller capacity that allows using storage resource as efficiently as possible.

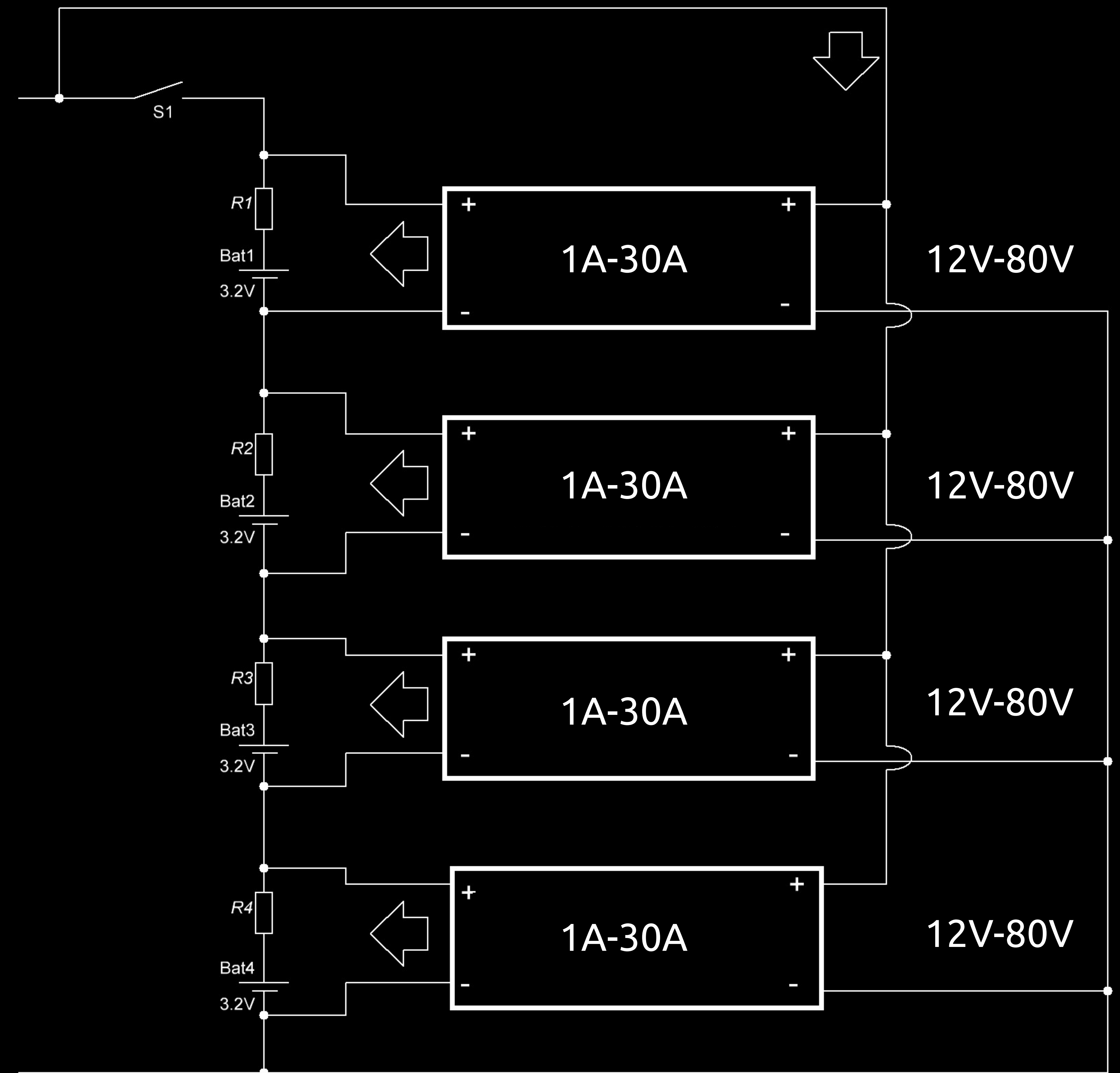

EFFICIENT CHARGING ALGORITHM

Charging process is controlled by VM5 LI-ION SYSTEMS which ensures a long service life of the storage devices and eliminates premature failure of the cells that are part of it.

Universal algorithms provide a stable and correct information exchange between VM5 LI-ION SYSTEMS and chargers of various manufacturers.*

**if a built-in CAN protocol is used, modification is required*

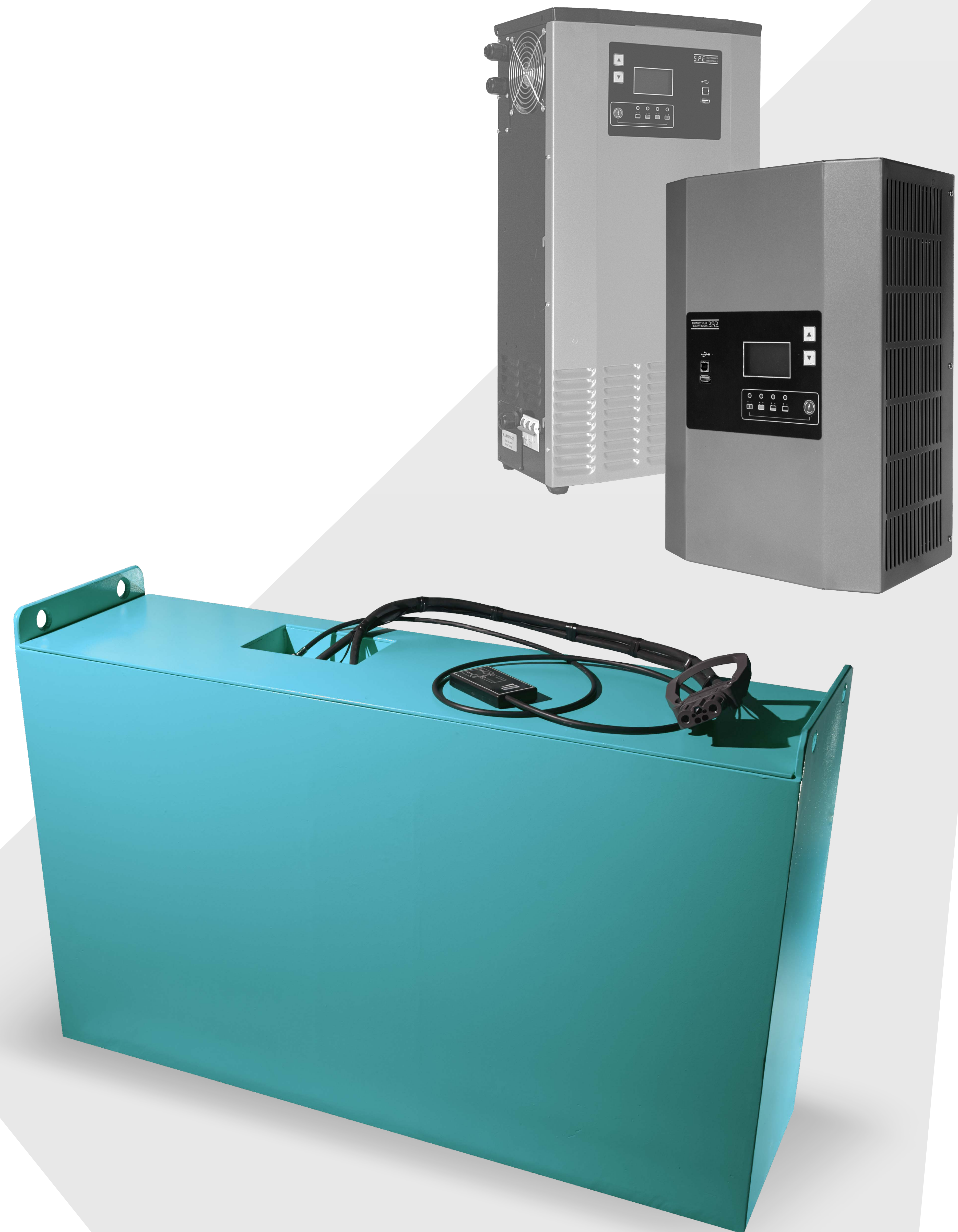

DESIGN OPTIONS

-35 °C

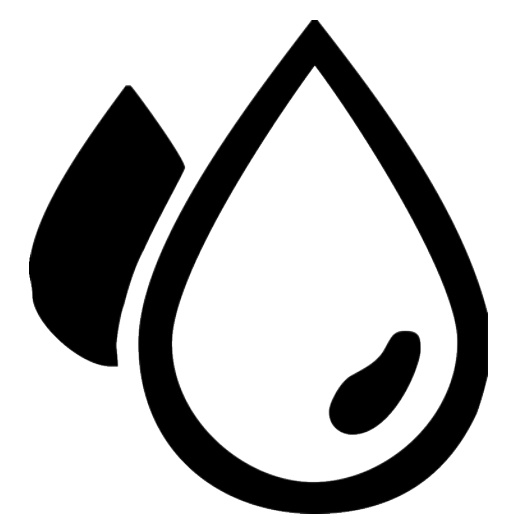

Sealed, dust-and moisture-proof design makes it possible to operate the battery in rooms with high humidity and dust.

This technology eliminates penetration of dust and condensation inside the storage device housing.

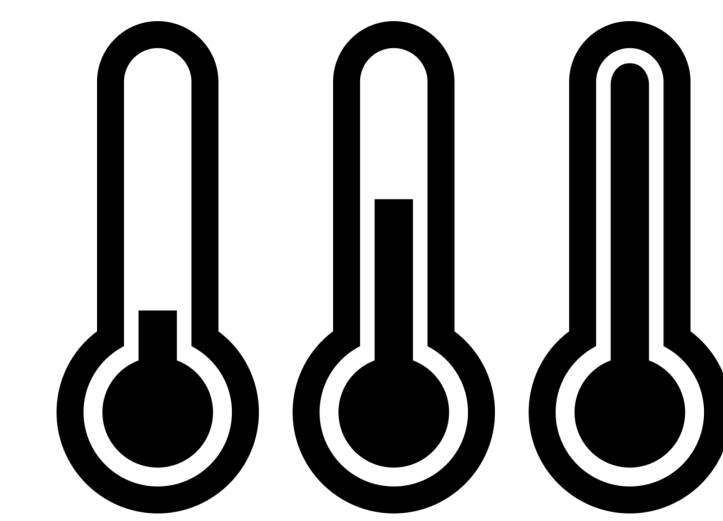

Uniform distribution of heating elements and / or thermal insulation materials expands possibilities of using the battery.

These design solutions allow using the storage devices at low temperatures, including in freezers.

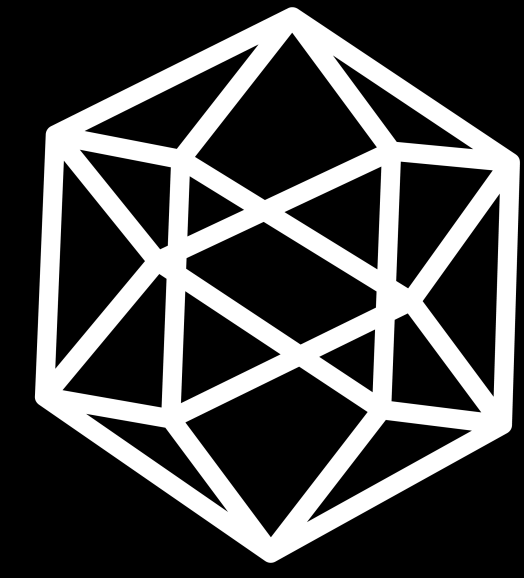

Li-ionSystems

Lithium-ion traction batteries



ONLINE MONITORING

The online monitoring system provides centralized monitoring of the battery fleet state and their operating modes that makes operation of the equipment efficient and safe

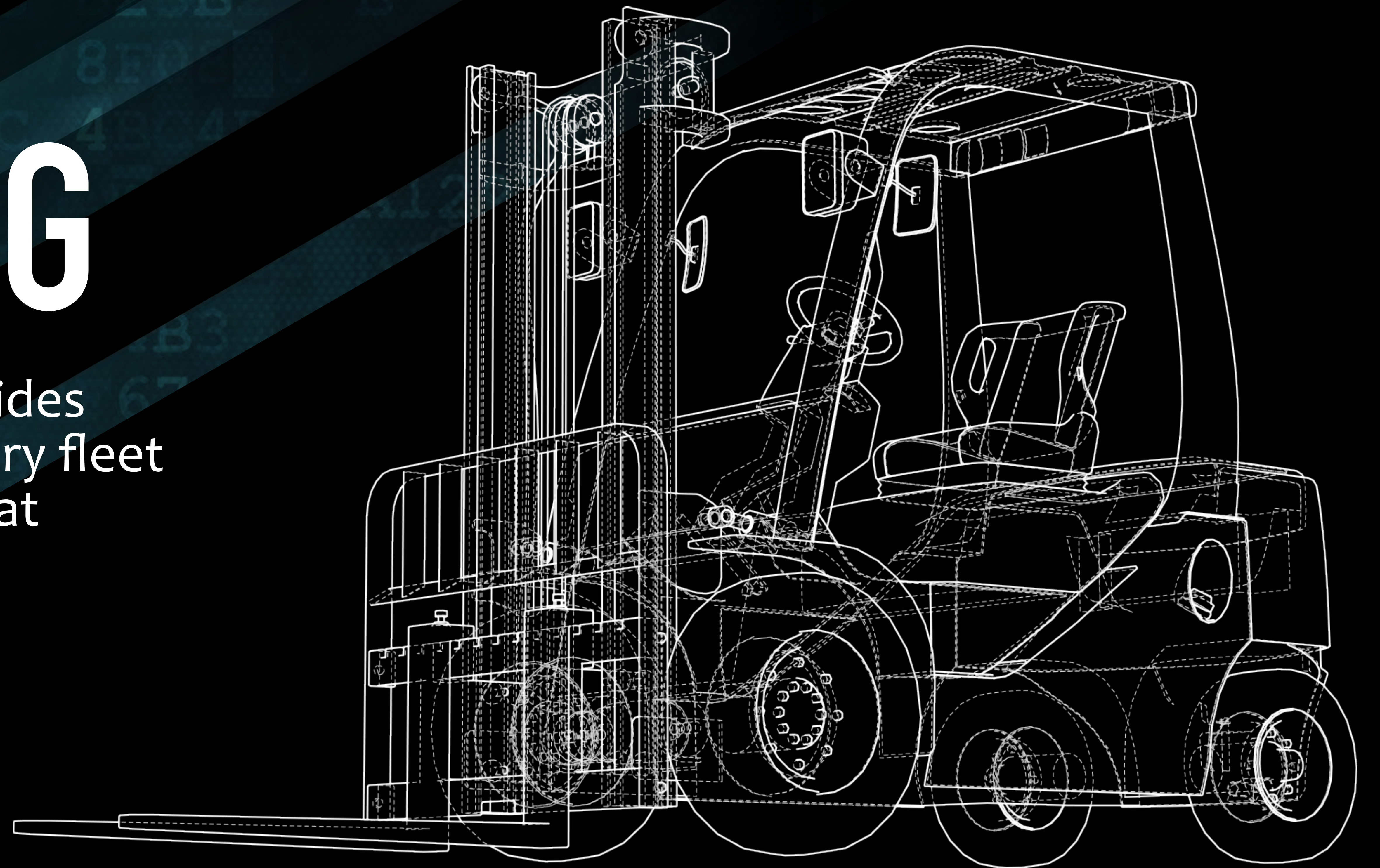

REMOTE MONITORING AND FORECASTING

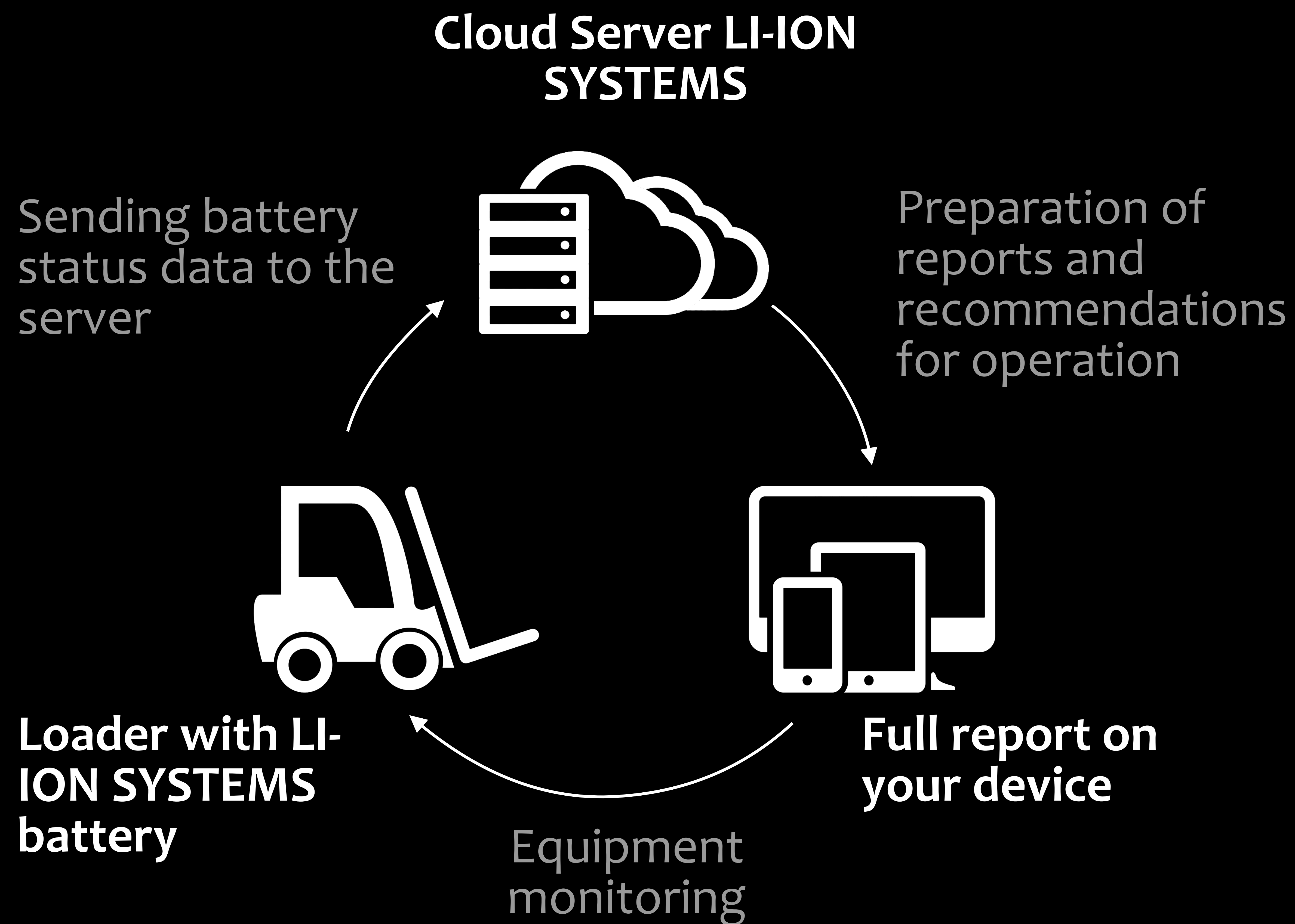

PARAMETER MONITORING

The monitoring system performs centralized monitoring of the key parameters of the battery state :

1. Charge level
2. Voltage
3. Current
4. Temperature

NON-STOP OPERATION

The system predicts failures of the energy storage device and eliminates downtime during the fleet operation.

MONITORING APPLICATION

Convenient access to data both at your work computer and on your smartphone screen

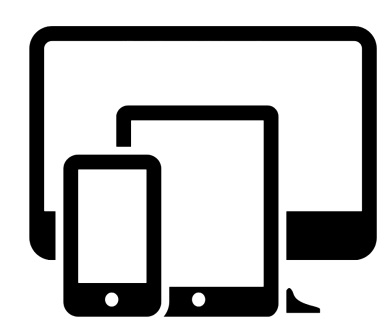

The intuitive interface of the application allows analyzing the battery state by key operational parameters.



Visualization of changes in the residual capacity, operating voltage, battery temperature and ratio of operating modes.

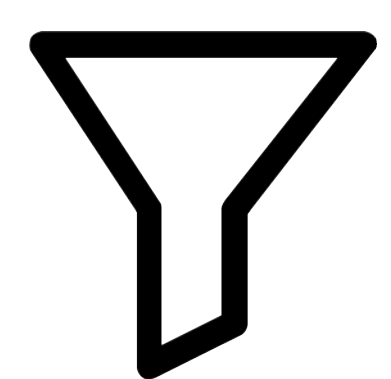

Filtering by city, warehouse, battery type and mode, sorting by operational parameters, and other features.

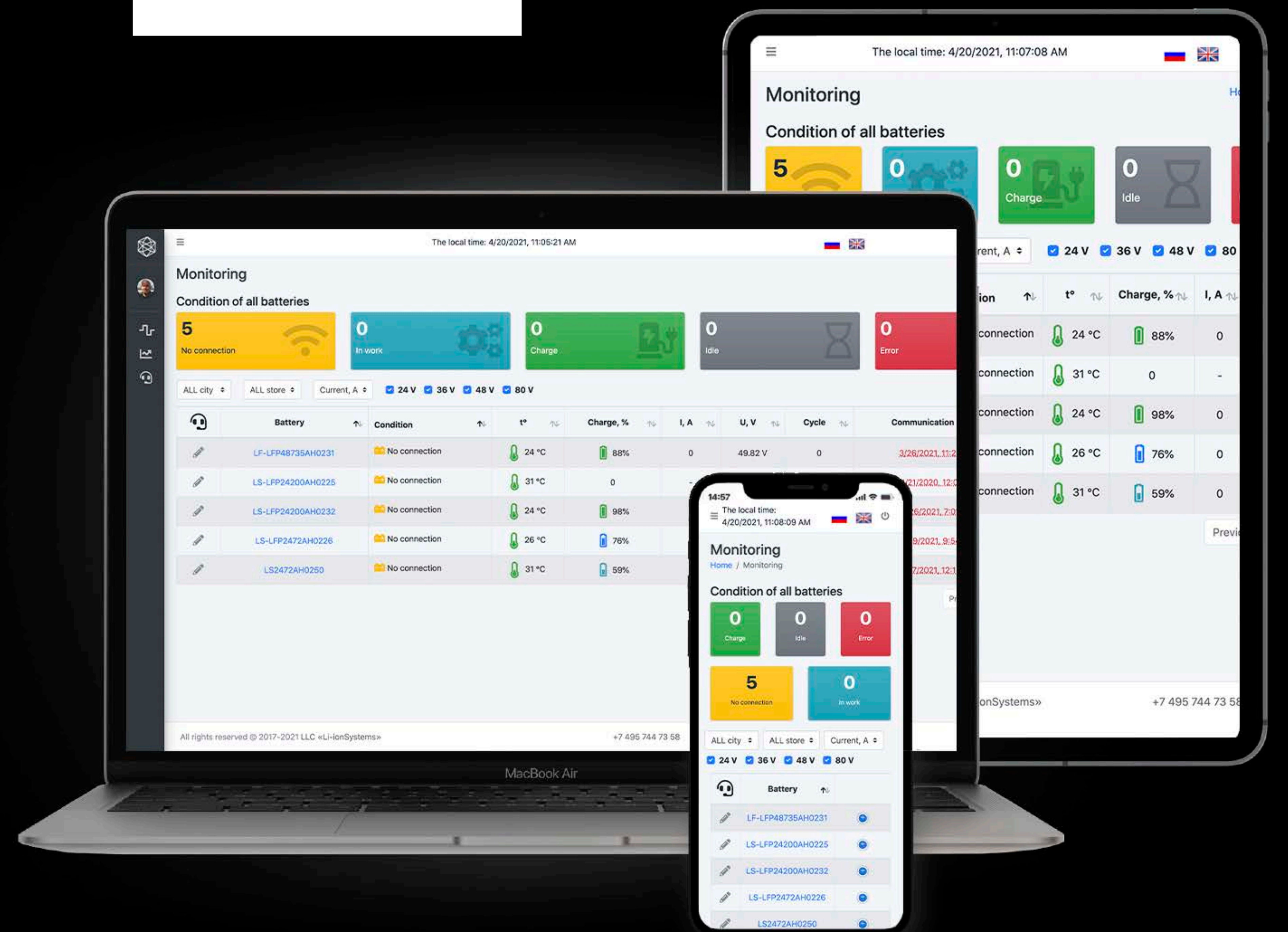

EASY AND SECURE ACCESS

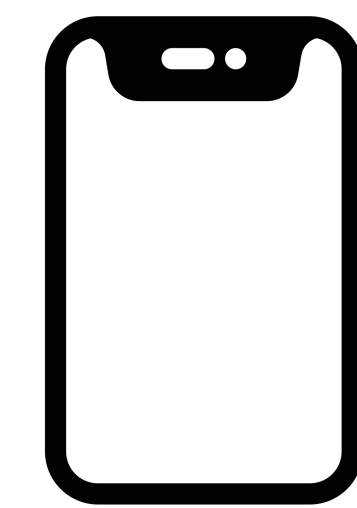

FROM ANY DEVICE

Access to the monitoring system is possible from any smart device which supports the browser.

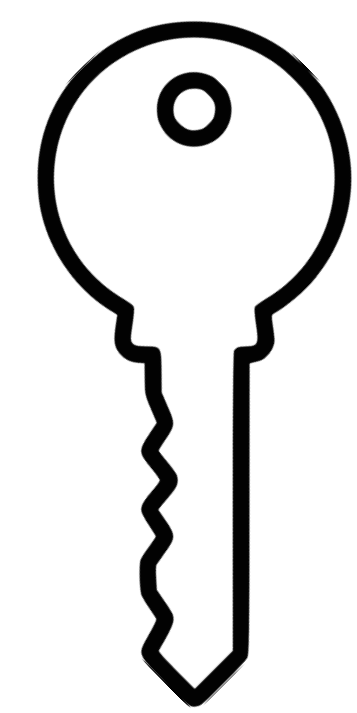

DATA ARE PROTECTED

The customer's personal username and password open access to the list of used batteries.



CONFIDENTIALITY

Preventing information leakage by encrypting data

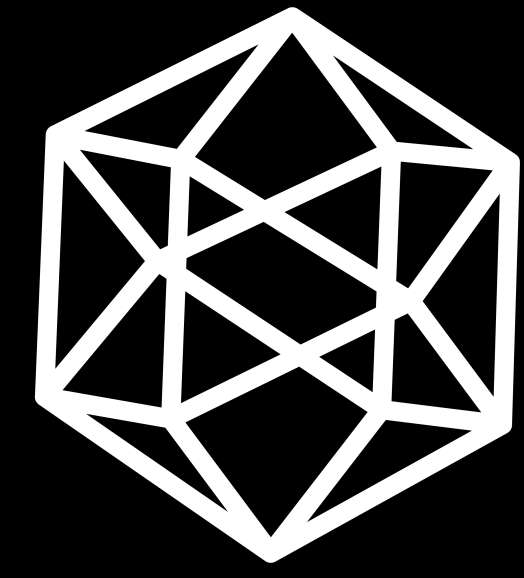

Li-ionSystems

Lithium-ion traction batteries

ECO-FRIENDLY

When using LIB technology, there are no toxic and corrosive emissions



BY PRESERVING NATURE, YOU SAVE YOUR CAPITAL

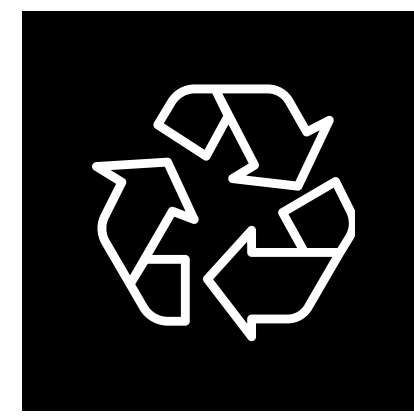

LIB technology allows complete recycling the battery after decommissioning.



During the LIB disposal, it is possible to extract cobalt, lithium, manganese and nickel from the batteries for their reuse in the production of new batteries.

LI-ION Systems buys-out its batteries after the end of exploitation.

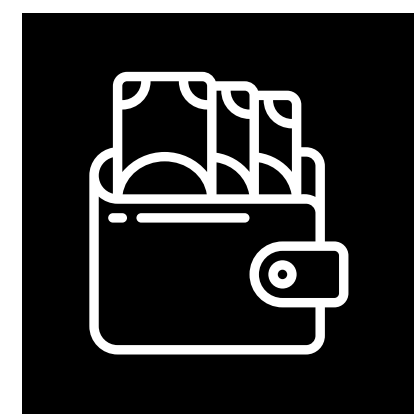

LIBs do not emit toxic substances that poison the ground. This preserves its cost and ability to change the category.



Reputation of an eco-oriented company allows attracting more knowledgeable and qualified employees and improving the company's image.

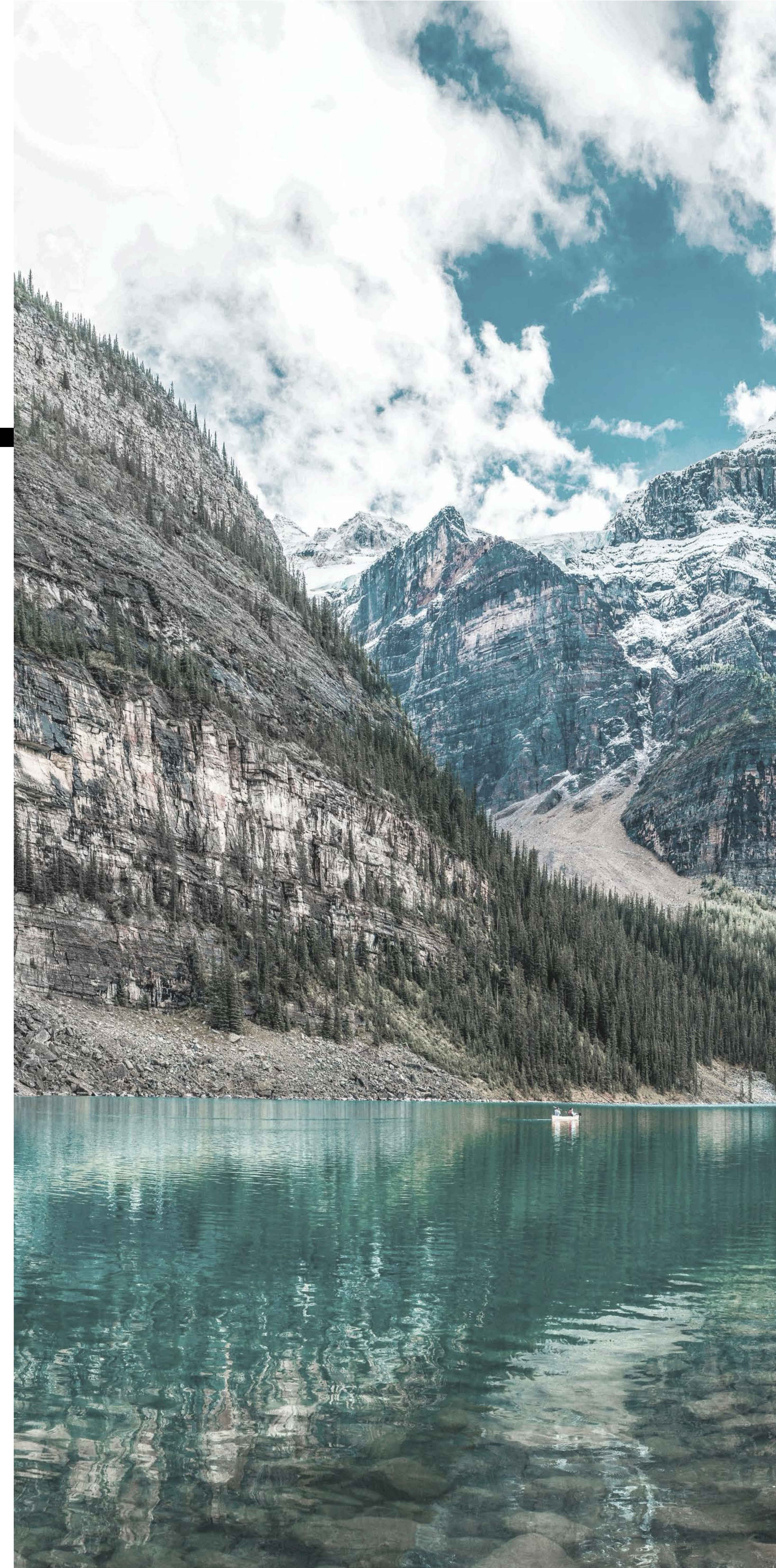

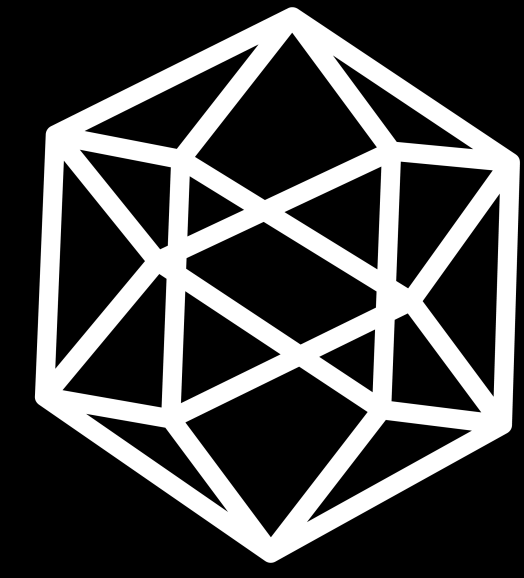

Li-ionSystems

Lithium-ion traction batteries

ECONOMY

The lithium-ion battery is the most advanced technology, and by choosing it, you automatically reduce your own infrastructure reequipment costs for the next 5-10 years

COST OF BATTERY EXPLOITATION

Comparison of total operating cost of lead-acid and Li-Ion batteries at the enterprise

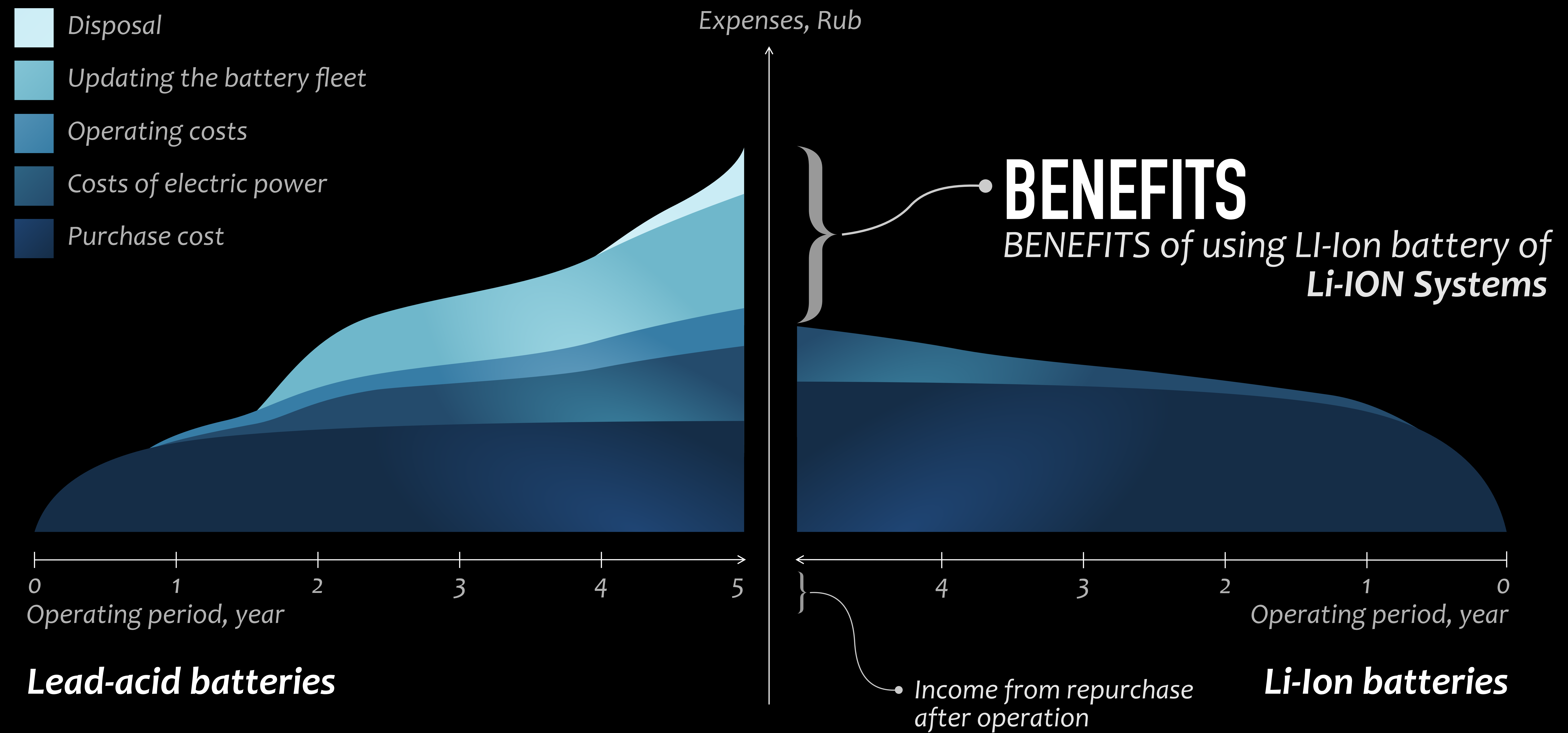

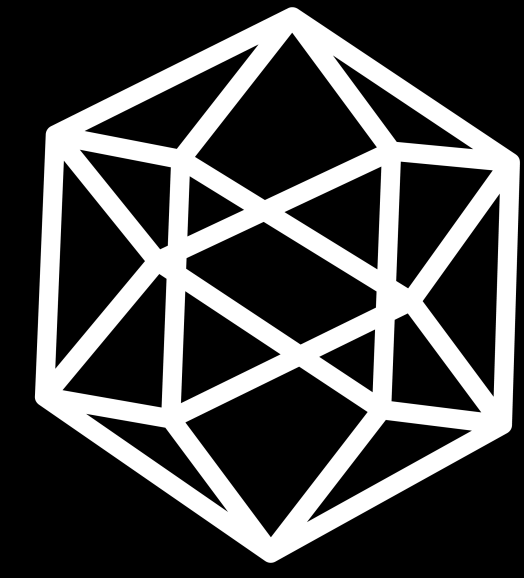

Li-ionSystems

Lithium-ion traction batteries

PROFITABLE PARTNERSHIP

We provide our customers not only with the most advanced technology, but also with a high level service

CHANGE YOUR BATTERIES TO BATTERIES OF LI-ION SYSTEMS



PAYBACK

Buyback of LI-ION SYSTEMS energy storage devices after operation.



TESTING ENERGY STORAGE DEVICE

Free test operation of LI-ION SYSTEMS energy storage devices.



TRADE IN

Purchase of lead-acid and gel batteries in payment for LI-ION SYSTEMS storage devices.



HIGH-LEVEL SERVICE



Free shipping to the central regions of Russia



Prompt production - from 2 weeks



Technical support service



Warranty - from 3-x years (without machine hours limit)



Training the Customer's service personnel



Provision of replacement storage devices for fleet from 30 pcs.

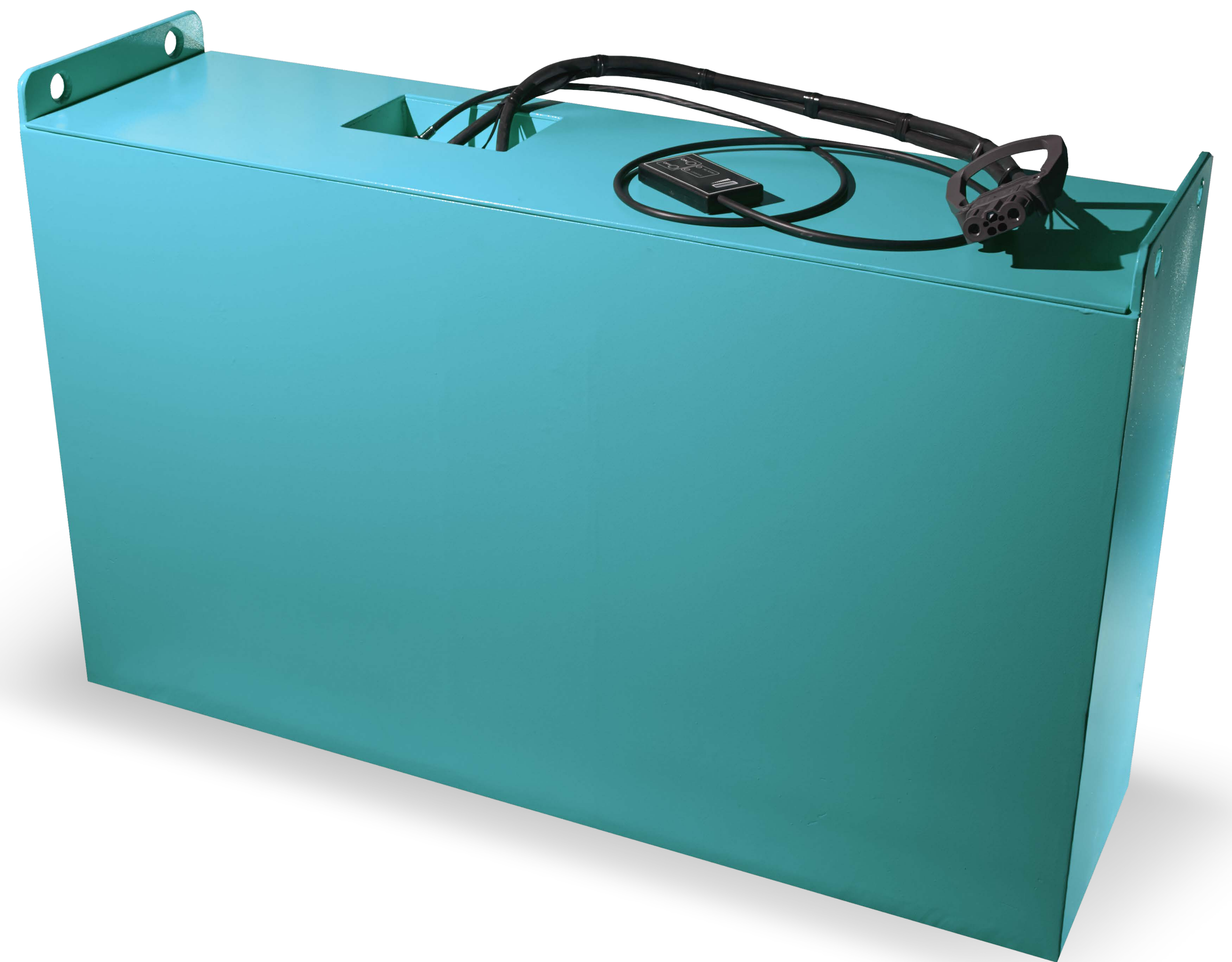

**YOUR ENERGY STORAGE DEVICE FROM
LI-ION SYSTEMS**

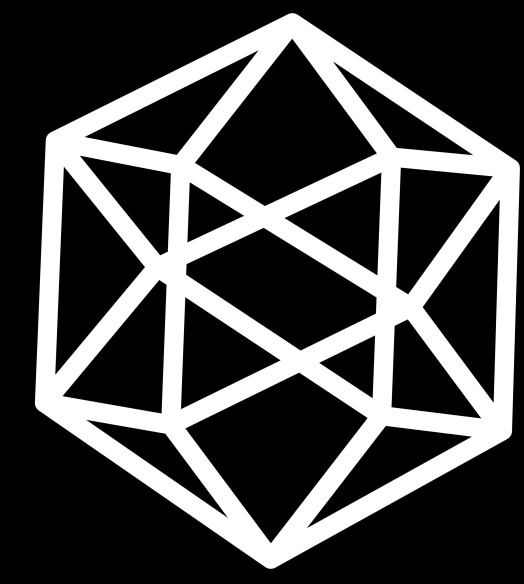

Li-ionSystems

Lithium-ion traction batteries

CONTACTS

www.lionsystems.ru

+7 (495) 744-73-58

info@lionsystems.ru



Website

Official website of the Li-ION Systems company

<http://www.lionsystems.ru/>



Products

Basic parameters of energy storage devices and chargers

<http://www.lionsystems.ru/product/>